

Features:

- 4 SMA electrical interfaces
- Designed to work with COTSWORKS Dual SFF transceivers
- Connector pin receptacles for fast and easy transceiver mounting
- Convenient test points for DDMI interface
- Easy to read LED indicators for visual function verification
- Easy access signal detect test points
- Modified Dual SFF test boards are available and made to fit customer requested shapes, sizes, and I/O

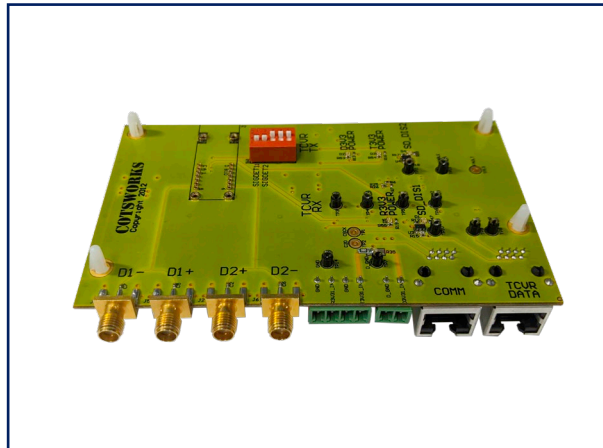

This high performance evaluation board allows for fast and reliable testing without the need for a final board design.

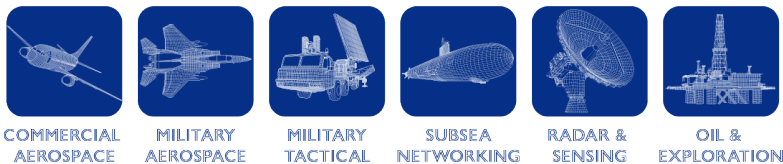

General Description

This electrical interface board is ideal for testing all features of the COTSWORKS SFF Dual Transmitter and SFF Dual Receiver components.

The dual SFF transceiver test board is designed to simplify early level testing without having to integrate the transceiver into a host board from pattern generation through electrical connectors.

This test board can become an interposer board, routing the electrical connection from our Transceiver Platform parts to a customer specified connector on a customer PCB.

Absolute Maximum Ratings

| PARAMETER | SYMBOL | MIN. | MAX. | UNIT | NOTES |
|------------------------|------------------|------|------|------|-------|
| Maximum Supply Voltage | V _{CC} | - | 3.47 | V | |
| Storage Temperature | T _{sto} | -55 | 105 | °C | |
| Operating Temperature | T _{OP} | -55 | 105 | °C | |



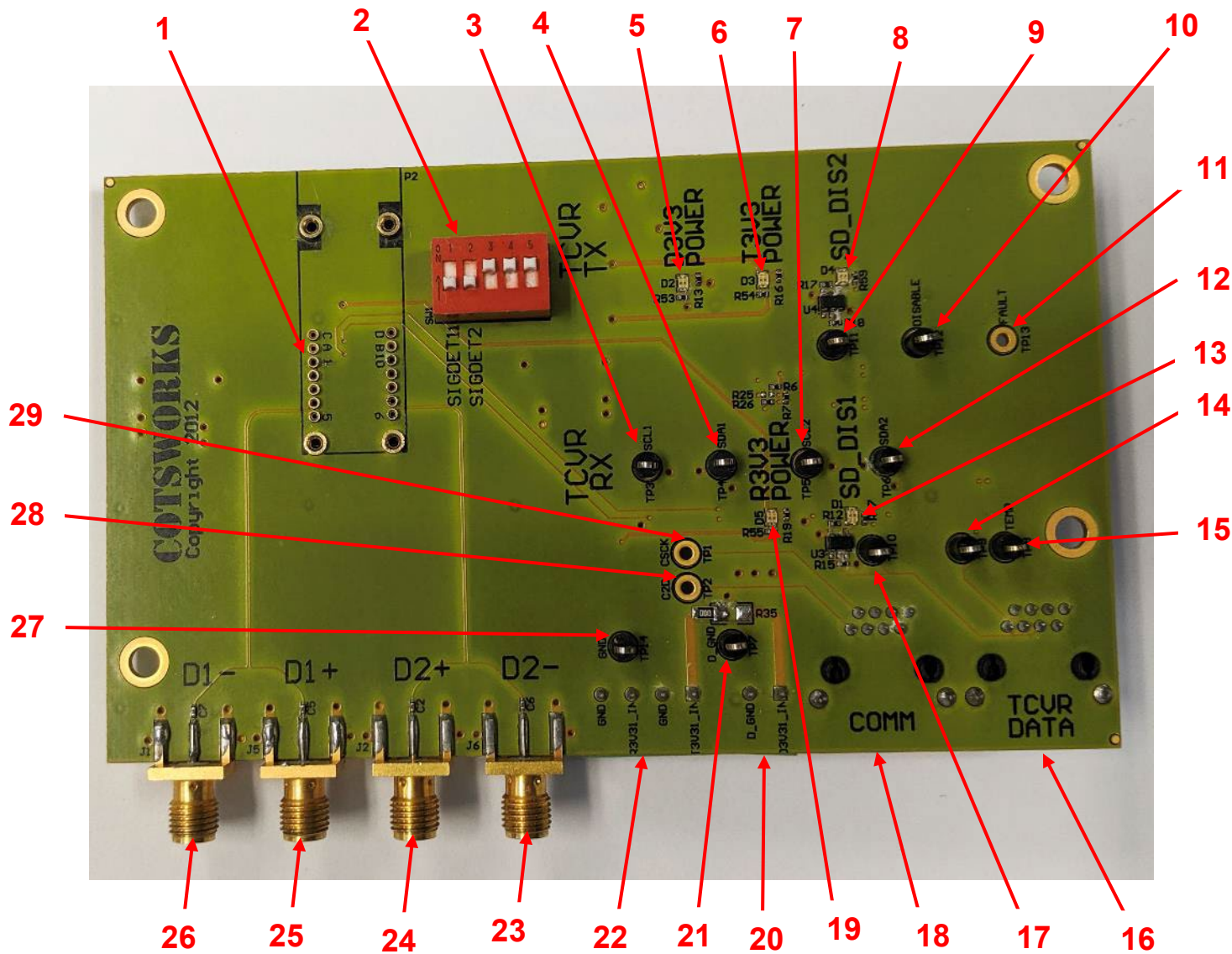
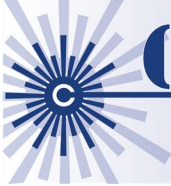

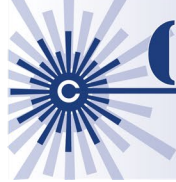

| | | |
|----|-----------------------------------|---|
| 1 | 2x7A Socket Dual Rx/Tx | Connect DUT pins to socket pins for power, communication, and functionality monitorization of DUT. |
| 2 | 5 Position DIP Switch | Flip switches 1 and 2 to the on/closed position to connect the signal detect function of both channels to the TX_Disable function. Switches 3, 4, and 5 are left unconnected. |
| 3 | Channel 1 SCL Test Point | If supported by the DUT, channel 1 communication through the I2C bus can be established through this test point. |
| 4 | Channel 1 SDA Test Point | If supported by the DUT, channel 1 communication through the I2C bus can be established through this test point. |
| 5 | Digital Power Indicator | The LED will turn on if there is 3.3V on the digital power plane supplied from location 20. Digital power is used to power the components on the eval board and does not power the DUT. |
| 6 | Channel 1 Power Indicator | The LED will turn on if there is 3.3V on the channel 1 power plane supplied from location 22. Digital power is used to power the components on the eval board and does not power the DUT. |
| 7 | Channel 2 SCL Test Point | If supported by the DUT, channel 2 communication through the I2C bus can be established through this test point. |
| 8 | Channel 2 SD_DIS Indicator | The LED will turn red if the voltage of SD_TDIS of channel 2 is high. The LED will turn green if the voltage of channel 2 is low. |
| 9 | Channel 2 SD Test Point | This test point can be used to measure the voltage on the SD pin for channel 2 on the DUT. If the voltage is measured high, the receiver on channel 2 of the DUT is receiving a signal. If the voltage is measured low, the channel 2 receiver of the DUT is not receiving a signal. |
| 10 | TX_Disable Test Point | This test point can be used to measure the voltage on the TX_DIS pin on the DUT. It can also be used to drive the TX_DIS pin on the DUT. If the test point is connected to GND, the Transmitter will be enabled. If the test point is connected to Vcc, the Transmitter will be disabled. |
| 11 | TX_Fault Test Point | This test point can be used to test the voltage on the TX_Fault pin on the DUT. If the voltage is measured high, a transmitter on the DUT is causing a fault. |
| 12 | Channel 2 SDA Test Point | If supported by the DUT, channel 2 communication through the I2C bus can be established through this test point. |
| 13 | Channel 1 SD_DIS Indicator | The LED will turn red if the voltage of SD_TDIS of channel 1 is high. The LED will turn green if the voltage of channel 1 is low. |
| 14 | Rate Select Test Point | This feature is not used. |
| 15 | Temperature Test Point | This test point can be used to measure the voltage from the temperature sensor on the eval board. |



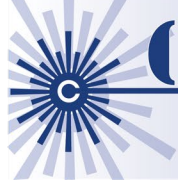

| | | |
|----|-----------------------------------|--|
| 16 | Transceiver I/O | A standard OTS Ethernet communication cable with a Dual SFF can be used for communication with features of the DUT. Contact COTSWORKS for the pinout details. |
| 17 | Channel 1 SD Test Point | This test point can be used to measure the voltage on the SD pin for channel 1 on the DUT. If the voltage is measured high, the receiver on channel 1 of the DUT is receiving a signal. If the voltage is measured low, the channel 1 receiver of the DUT is not receiving a signal. |
| 18 | Communications I/O | A standard OTS Ethernet communication cable with a Dual SFF can be used for communication with the DUT and eval board EEPROM through I2C. Contact COTSWORKS for the pinout details. |
| 19 | Channel 2 Power Indicator | The LED will turn on if there is 3.3V on the channel 2 power plane supplied from location 22. Digital power is used to power the components on the eval board and does not power the DUT. |
| 20 | Digital Power | Connect the supplied 2-pin power cable to 3.3V. Digital power is used to power the components on the eval board and does not power the DUT. |
| 21 | GND Test Point | This test point can be used to verify that the GND plane is at its correct reference voltage. |
| 22 | Transceiver Power | Connect the supplied 4-pin power cable to 3.3V. Transceiver power is used to power the DUT and does not power the components on the eval board. |
| 23 | Channel 2 Inverted I/O | Provide inverted input/output signal for channel 2 of the optical transceiver through a 50Ω SMA cable. Check DUT datasheet for input/output signal specifications. |
| 24 | Channel 2 Non-inverted I/O | Provide non-inverted input/output signal for channel 2 of the optical transceiver through a 50Ω SMA cable. Check DUT datasheet for input/output signal specifications. |
| 25 | Channel 1 Non-inverted I/O | Provide non-inverted input/output signal for channel 1 of the optical transceiver through a 50Ω SMA cable. Check DUT datasheet for input/output signal specifications. |
| 26 | Channel 1 Inverted I/O | Provide inverted input/output signal for channel 1 of the optical transceiver through a 50Ω SMA cable. Check DUT datasheet for input/output signal specifications. |
| 27 | GND Test Point | This test point can be used to verify that the GND plane is at its correct reference voltage. |
| 28 | C2D Test Point | This feature is not used. |
| 29 | CSCK Test Point | This feature is not used. |



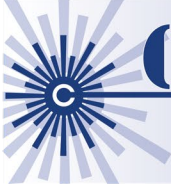

Test Board Modification into Interposer Board

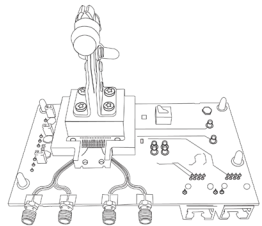
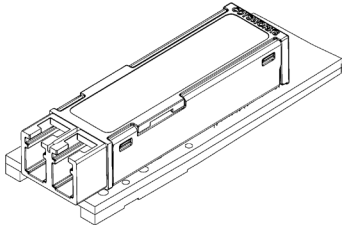
| | | |
|---|---|---|
|  |  | <p>Possible Modifications Include</p> <ul style="list-style-type: none"> • Custom form factors, connectors, and layout • Ruggedization for shock, vibration, and environmental requirements |
|---|---|---|

Ordering Information

| TESTBD-SFF-2X | -XX |
|---|---|
| <p>Dual SFF Transceiver Eval Board</p> | <p>Plate Option</p> <p>P(): Plate Stand Included</p> <p>NP: Plate Stand Not Included</p> |

Example part number: TESTBD-SFF-2X-P [Dual SFF Transceiver Eval Board with plate stand.]

Contact sales@COTSWORKS.com for mechanical dimensional information, Interposer Board modifications, and other configuration options.

COTSWORKS and the COTSWORKS logo are registered trademarks of COTSWORKS, INC.
COTSWORKS reserves the right to change, alter, or revise this document without notice unless otherwise agreed to.

